

# CP - DCP

## CENTRIFUGAL CIRCULATING PUMPS WITH IN-LINE CONNECTIONS



Circulating pumps with in-line connections, suitable for civil and industrial installations for heating, air-conditioning and hot water for domestic use.

Pump body and motor support in cast iron.

PN 16 flanged suction and delivery connections with threaded holes for control pressure gauges.

Technopolymer impeller and carbon/ceramic mechanical seal.

Three-phase, four-pole, asynchronous motor with external ventilation. To protect the motor it is advisable to use a thermal overload protection complying with the regulations in force.

**Operating range:** from 3 to 240 m<sup>3</sup>/h with head up to 68 metres.

**Liquid temperature range:** from -15°C to +120°C.

**Pumped liquid characteristics:** clean, free from solids or abrasive substances, not viscous, not aggressive, not crystallised and chemically neutral.

**Maximum ambient temperature:** +40°C

**Maximum working pressure:** 16 bar (1600 kPa).

**Protection level:** IP 55

**Insulation class:** F

PN 16 counter flanges on request.

## ELECTRICAL DATA

CP

MODEL	VOLTAGE 50 Hz	N r.p.m.	P1 MAX	P2 NOMINAL		In A
				kW	HP	
CP 40/1900 T	3x230-400 V~	2910	1,1	0,75	1	4,5-2,6
CP 40/2300 T	3x230-400 V~	2870	1,45	1,1	1,5	5,2-3
CP 40/2700 T	3x230-400 V~	2850	1,89	1,5	2	6,4-3,7
CP 40/3500 T	3x230-400 V~	2880	2,53	2,21	3	9-5,2
CP 40/3800 T	3x230-400 V~	2900	3,54	3	4	11-6,4
CP 40/4700 T	3x230-400 V~	2900	4,87	4	5,5	15,2-8,8
CP 40/5500 T	3x400 V~Δ*	2900	6,57	5,5	7,5	11,3
CP 40/6200 T	3x400 V~Δ*	2900	9,18	7,5	10	15,8
CP 50/2200 T	3x230-400 V~	2870	1,42	1,1	1,5	5-2,9
CP 50/2600 T	3x230-400 V~	2860	1,89	1,5	2	6,2-3,6
CP 50/3100 T	3x230-400 V~	2870	2,51	2,2	3	9-5,2
CP 50/4100 T	3x230-400 V~	2910	3,8	4	5,5	7,4
CP 50/4600 T	3x400 V~Δ*	2900	6,57	5,5	7,5	11,3
CP 50/5100 T	3x400 V~Δ*	2900	9,18	7,5	10	15,8
CP 50/5650 T	3x400 V~Δ*	2900	9,18	7,5	10	15,8
CP 65/1700 T	3x230-400 V~	2900	2,53	2	2,7	7,7-4,4
CP 65/2100 T	3x230-400 V~	2900	3,54	3	4	11-6,4
CP 65/2550 T	3x230-400 V~	2900	4,87	4	5,5	15,2-8,8
CP 65/3250 T	3x400 V~Δ*	2900	6,57	5,5	7,5	11,3
CP 65/3700 T	3x400 V~Δ*	2900	9,18	7,5	10	12,8
CP 65/5100 T	3x400 V~Δ*	2900	12,46	10	13,5	15,8
CP 65/5800 T	3x400 V~Δ*	2900	15,13	12,5	17	27
CP 80/3050 T	3x400 V~Δ*	2900	12,46	10	13,5	22,5
CP 80/3650 T	3x400 V~Δ*	2900	15,13	12,5	17	27
CP 80/4100 T	3x400 V~Δ*	2900	17,94	15	20	32
CP 80/4400 T	3x400 V~Δ*	2900	17,94	15	20	32
CP 80/5100 T	3x400 V~Δ*	2900	21,3	18,5	25	38
CP 80/5700 T	3x400 V~Δ*	2900	25,25	22	30	44,5
CP 100/2400 T	3x400 V~Δ*	2900	12,46	10	13,5	22,5
CP 100/2850 T	3x400 V~Δ*	2900	15,13	12,5	17	27
CP 100/3400 T	3x400 V~Δ*	2900	17,94	15	20	32
CP 100/4200 T	3x400 V~Δ*	2900	21,3	18,5	25	38
CP 100/4700 T	3x400 V~Δ*	2900	25,25	22	30	44,5
CP 100/5500 T	3x400 V~Δ*	2900	34,12	30	40	58
CP 100/5700 T	3x400 V~Δ*	2900	41,76	37	50	71
CP 100/6800 T	3x400 V~Δ*	2900	41,76	37	50	71

\* Star (Δ) starting is possible

# CP - HYDRAULIC DATA

2 POLES

## CP 40

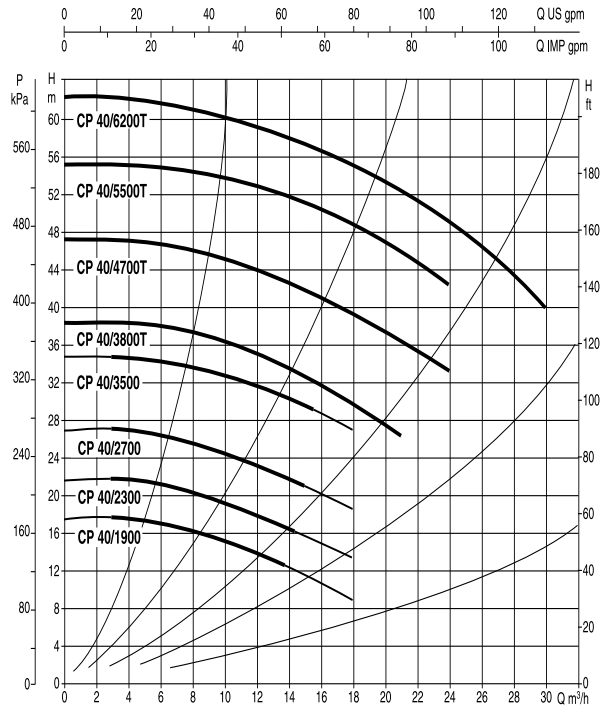

## CP 50

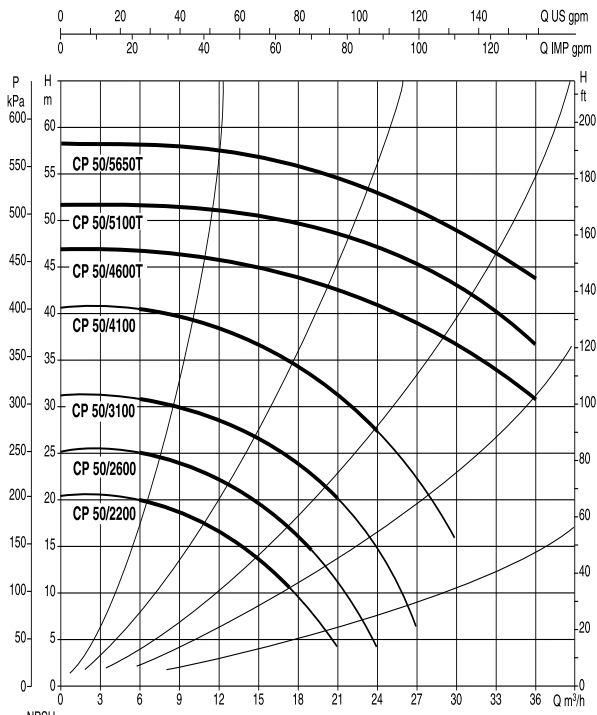

## CP 65

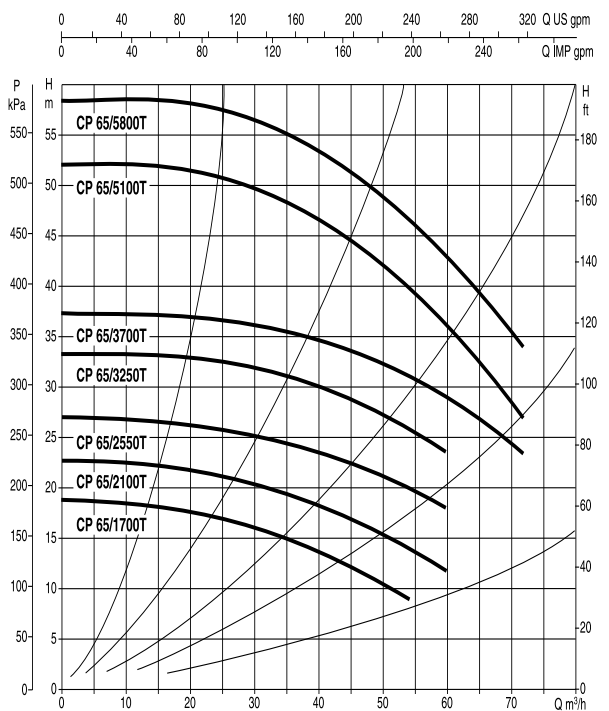

# CP - HYDRAULIC DATA

2 POLES

## CP 80

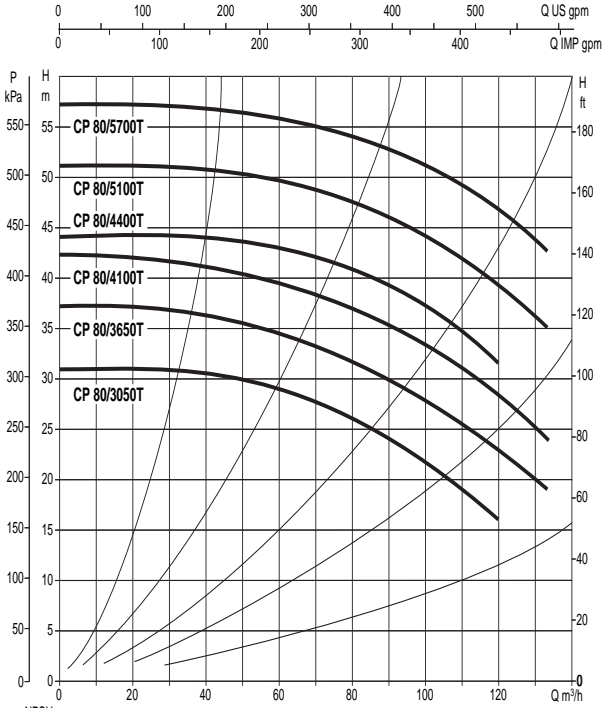

## CP 100

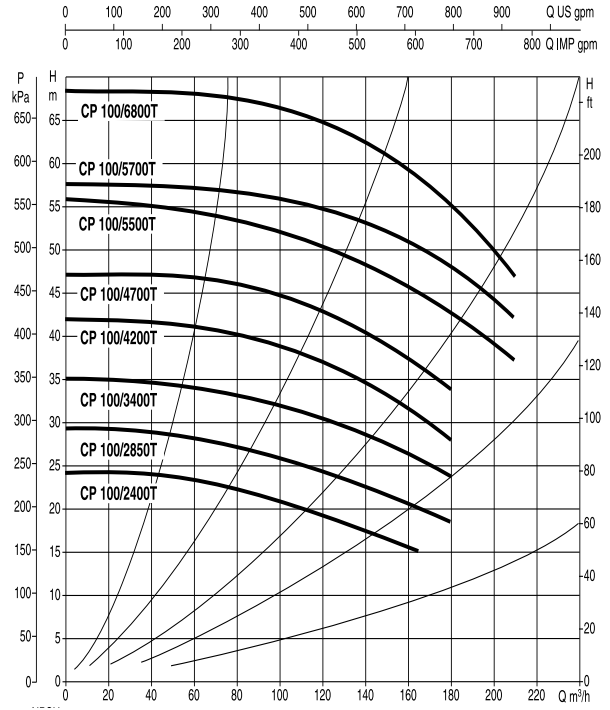

# DIMENSIONS

CP

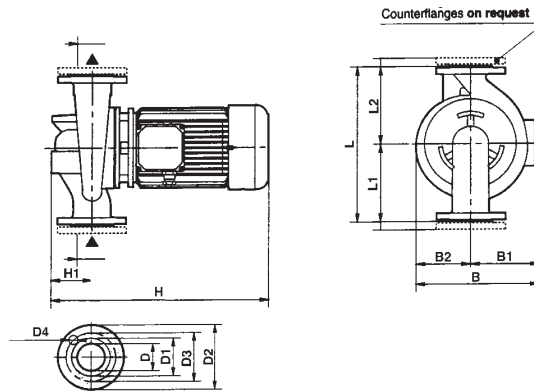

MODEL	L	L1	L2	B	B1	B2	H	H1	D	D1	D3	D2	D4	PACKAGING DIMENSIONS			VOLUME m <sup>3</sup>	WEIGHT Kg
														L/A	L/B	H		
CP 40/1900 T	390	200	190	231	118	113	453	95	40 PN16	88	150	110	4 slots Ø 14	680	330	580	0,13	41
CP 40/2300 T	390	200	190	231	118	113	453	95	40 PN16	88	150	110		680	330	580	0,13	41
CP 40/2700 T	390	200	190	231	118	113	453	95	40 PN16	88	150	110		680	330	580	0,13	43,5
CP 40/3500 T	390	200	190	231	118	113	453	95	40 PN16	88	150	110		680	330	580	0,13	48,8
CP 40/3800 T	320	170	150	257	149	108	485	100	40 PN6	88	150	110		450	270	465	0,04	37
CP 40/4700 T	380	200	180	286	159	127	535	100	40 PN6	88	150	110		450	270	465	0,04	50
CP 40/5500 T	380	200	180	286	159	127	535	100	40 PN6	88	150	110		450	270	465	0,04	55
CP 40/6200 T	380	200	180	286	159	127	535	100	40 PN6	88	150	110		450	270	465	0,04	56
CP 50/2200 T	425	225	200	233	120	113	463	105	50 PN16	102	165	125	4 slots Ø 18	680	330	580	0,13	46,6
CP 50/2600 T	425	225	200	233	120	113	463	105	50 PN16	102	165	125		680	330	580	0,13	49,5
CP 50/3100 T	425	225	200	233	120	113	537	105	50 PN16	102	165	125		680	330	580	0,13	52,8
CP 50/4100 T	425	225	200	233	120	113	537	105	50 PN16	102	165	125		680	330	580	0,13	61
CP 50/4600 T	400	220	180	290	159	131	545	110	50 PN10	102	165	125		520	320	535	0,06	56
CP 50/5100 T	400	220	180	290	159	131	545	110	50 PN10	102	165	125		520	320	535	0,06	57
CP 50/5650 T	400	220	180	290	159	131	545	110	50 PN10	102	165	125	520	320	535	0,06	64	
CP 65/1700 T	360	205	155	226	118	108	485	140	65 PN10	122	185	145	4 slots Ø 18	450	270	465	0,04	32
CP 65/2100 T	360	205	155	257	149	108	525	140	65 PN10	122	185	145		520	320	535	0,05	39
CP 65/2550 T	360	205	155	267	159	108	565	140	65 PN10	122	185	145		520	320	535	0,05	43
CP 65/3250 T	400	220	180	281	159	122	575	140	65 PN10	122	185	145		520	320	535	0,06	54
CP 65/3700 T	400	220	180	306	184	122	680	140	65 PN10	122	185	145		470	320	735	0,08	61
CP 65/5100 T	440	240	200	320	184	136	680	140	65 PN10	122	185	145		580	360	585	0,10	70
CP 65/5800 T	440	240	200	320	184	136	680	140	65 PN10	122	185	145	580	360	585	0,10	77	
CP 80/3050 T	440	240	200	315	184	131	700	160	80 PN10	138	200	160	4 slots Ø 18	580	360	585	0,10	72
CP 80/3650 T	440	240	200	315	184	131	700	160	80 PN10	138	200	160		580	360	585	0,10	79
CP 80/4100 T	440	240	200	315	184	131	700	160	80 PN10	138	200	160		580	360	585	0,10	85
CP 80/4400 T	500	275	225	330	184	146	700	160	80 PN10	138	200	160		-	-	-	0,12	91
CP 80/5100 T	500	275	225	375	229	146	860	160	80 PN10	138	200	160		-	-	-	0,16	124
CP 80/5700 T	500	275	225	375	229	146	860	160	80 PN10	138	200	160		-	-	-	0,16	142
CP 100/2400 T	525	300	225	320	184	136	730	190	100 PN10	158	220	180	8 slots Ø 18	-	-	-	0,12	76
CP 100/2850 T	525	300	225	320	184	136	730	190	100 PN10	158	220	180		-	-	-	0,12	84
CP 100/3400 T	525	300	225	320	184	136	730	190	100 PN10	158	220	180		-	-	-	0,12	91
CP 100/4200 T	550	300	250	386	230	156	890	190	100 PN10	158	220	180		-	-	-	0,19	135
CP 100/4700 T	550	300	250	386	230	156	890	190	100 PN10	158	220	180		-	-	-	0,19	158
CP 100/5500 T	550	300	250	413	257	156	995	190	100 PN10	158	220	180		-	-	-	0,23	195
CP 100/5700 T	550	300	250	413	257	156	995	190	100 PN10	158	220	180		-	-	-	0,23	213
CP 100/6800 T	600	320	280	433	257	176	995	190	100 PN10	158	220	180		-	-	-	0,26	220

## ELECTRICAL DATA

DCP

MODEL	VOLTAGE 50 Hz	N r.p.m.	P1 MAX	P2 NOMINAL		In A
				kW	HP	
DCP 40/1250 T	3x230-400 V ~	2900	0,83	0,55	0,75	2,8-1,6
DCP 40/1650 T	3x230-400 V ~	2900	1,05	0,75	1	3,3-1,9
DCP 40/2050 T	3x230-400 V ~	2900	1,33	1	1,35	4,2-2,4
DCP 40/2450 T	3x230-400 V ~	2900	2,07	1,5	2	6,2-3,6
DCP 50/1550 T	3x230-400 V ~	2900	2,07	1,5	2	6,2-3,6
DCP 50/1900 T	3x230-400 V ~	2900	2,53	2	2,7	7,7-4,4
DCP 50/2450 T	3x230-400 V ~	2900	3,54	3	4	11-6,4
DCP 50/3000 T	3x230-400 V ~	2900	3,54	3	4	11-6,4
DCP 50/3650 T	3x230-400 V ~	2900	4,87	4	5,5	15,2-8,8
DCP 65/2300 T	3x230-400 V ~	2900	3,54	3	4	11-6,4
DCP 65/2650 T	3x230-400 V ~	2900	4,87	4	5,5	15,2-8,8
DCP 65/3250 T	3x400 V ~ Δ*	2900	6,57	5,5	7,5	11,3
DCP 65/3700 T	3x400 V ~ Δ*	2900	9,18	7,5	10	15,8
DCP 80/2530 T	3x400 V ~ Δ*	2900	9,18	7,5	10	15,8
DCP 80/3050 T	3x400 V ~ Δ*	2900	12,46	10	13,5	22,5
DCP 80/3650 T	3x400 V ~ Δ*	2900	15,13	12,5	17	27
DCP 80/4100 T	3x400 V ~ Δ*	2900	17,94	15	20	32
DCP 100/3300 T	3x400 V ~ Δ*	2900	15,13	12,5	17	27
DCP 100/3750 T	3x400 V ~ Δ*	2900	17,94	15	20	32
DCP 100/2450 T	3x400 V ~ Δ*	2900	12,46	10	13,5	22,5
DCP 100/2750 T	3x400 V ~ Δ*	2900	15,13	12,5	17	27
DCP 100/2800 T	3x400 V ~ Δ*	2900	17,94	15	20	32
DCP 100/2900 T	3x400 V ~ Δ*	2900	17,94	15	20	32

## DCP - HYDRAULIC DATA

2 POLES

### DCP 40

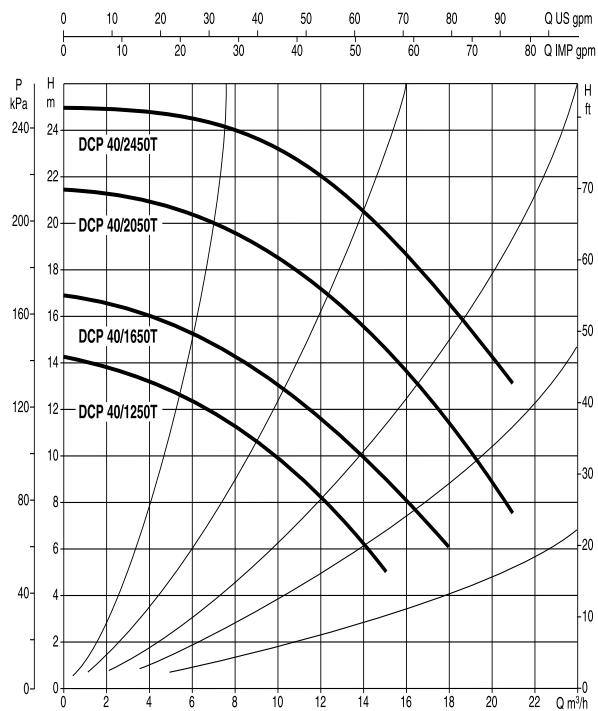

### DCP 50

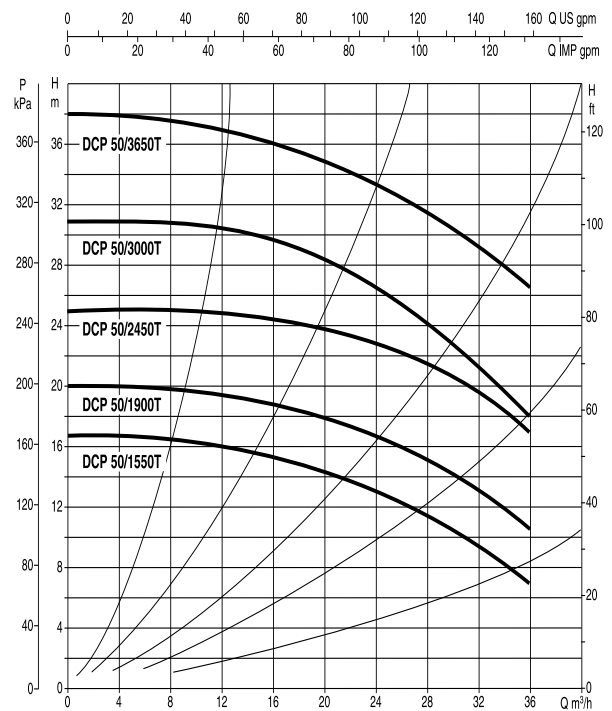

For back-to-back versions the electrical data refer to the functioning motor only.

# DCP - HYDRAULIC DATA

2 POLES

## DCP 65

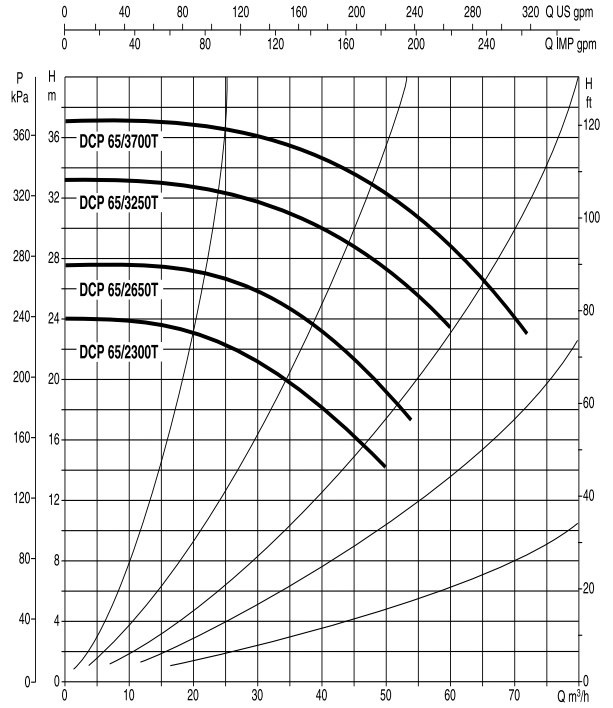

## DCP 80

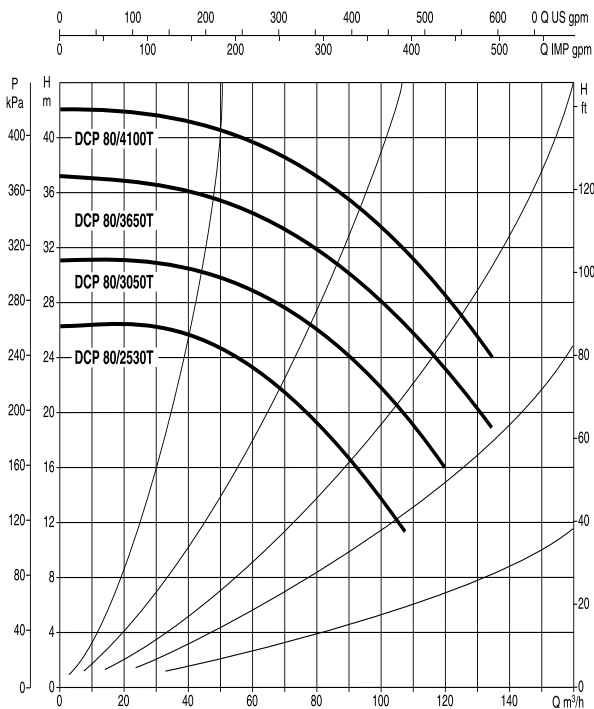

## DCP 100

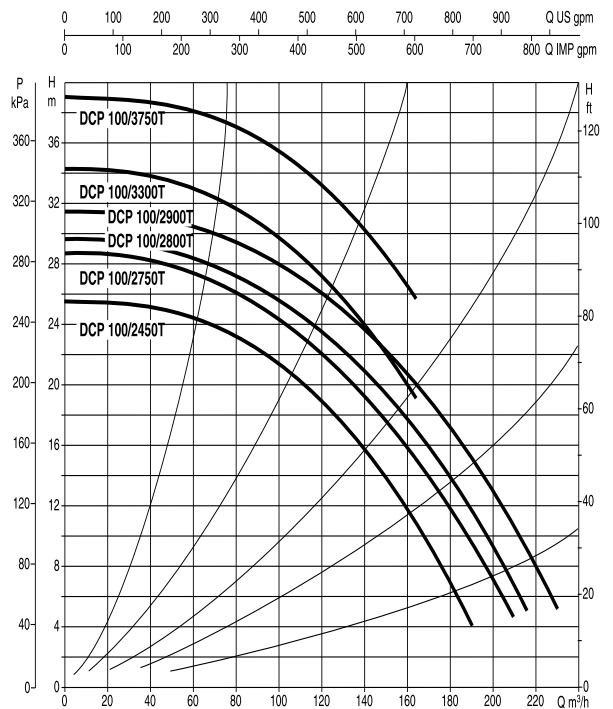

For back-to-back versions the electrical data refer to the functioning motor only.

# DIMENSIONS

DCP

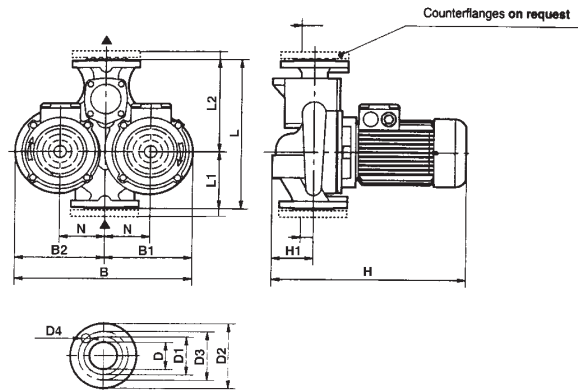

MODEL	L	L1	L2	B	B1	B2	H	H1	N	D	D1	D2	D3	D4	PACKAGING DIMENSIONS			VOLUME m <sup>3</sup>	WEIGHT Kg
															L/A	L/B	H		
DCP 40/1250 T	340	130	210	397	200	197	425	100	100	40 PN6	88	150	110	4 slots Ø 18	520	320	535	0,06	50
DCP 40/1650 T	340	130	210	397	200	197	425	100	100	40 PN6	88	150	110		520	320	535	0,06	50
DCP 40/2050 T	340	130	210	397	200	197	445	100	100	40 PN6	88	150	110		520	320	535	0,06	52
DCP 40/2450 T	340	130	210	397	200	197	445	100	100	40 PN6	88	150	110		520	320	535	0,06	54
DCP 50/1550 T	365	145	220	427	217	210	455	110	105	50 PN10	102	165	125	4 slots Ø 18	520	320	535	0,07	56
DCP 50/1900 T	365	145	220	427	217	210	455	110	105	50 PN10	102	165	125		520	320	535	0,07	58
DCP 50/2450 T	365	145	220	427	217	210	455	110	105	50 PN10	102	165	125		520	320	535	0,07	66
DCP 50/3000 T	365	145	220	480	217	210	495	110	105	50 PN10	102	165	125		580	360	585	0,09	56
DCP 50/3650 T	410	170	240	480	245	235	535	110	120	50 PN10	102	165	125	580	360	585	0,11	86	
DCP 65/2300 T	410	170	240	543	245	235	485	110	120	65 PN10	122	185	145	4 slots Ø 18	580	360	585	0,11	67
DCP 65/2650 T	450	180	270	543	275	268	495	130	140	65 PN10	122	185	145		-	-	-	0,12	81
DCP 65/3250 T	450	180	270	543	275	268	565	130	140	65 PN10	122	185	145		-	-	-	0,14	101
DCP 65/3700 T	450	180	270	543	275	268	670	130	140	65 PN10	122	185	145		-	-	-	0,16	125
DCP 80/2530 T	450	180	270	550	275	268	565	130	135	80 PN10	138	200	160	8 slots Ø 18	-	-	-	0,14	110
DCP 80/3050 T	510	205	305	550	280	270	690	150	135	80 PN10	138	200	160		-	-	-	0,19	141
DCP 80/3650 T	510	205	305	550	280	270	690	150	140	80 PN10	138	200	160		-	-	-	0,19	162
DCP 80/4100 T	510	205	305	670	280	270	690	150	135	80 PN10	138	200	160		-	-	-	0,24	175
DCP 100/3300 T	630	240	390	670	325	345	720	180	165	100 PN10	158	220	180	8 slots Ø 18	-	-	-	0,30	162
DCP 100/3750 T	630	240	390	670	325	345	720	180	165	100 PN10	158	220	180		-	-	-	0,30	162
DCP 100/2450 T	630	240	390	670	325	345	720	180	165	100 PN10	158	220	180		-	-	-	0,30	162
DCP 100/2750 T	630	240	390	670	325	345	720	180	165	100 PN10	158	220	180		-	-	-	0,30	162
DCP 100/2800 T	630	240	390	670	325	345	720	180	165	100 PN10	158	220	180		-	-	-	0,30	162
DCP 100/2900 T	630	240	390	670	325	345	720	180	165	100 PN10	158	220	180		-	-	-	0,30	162