

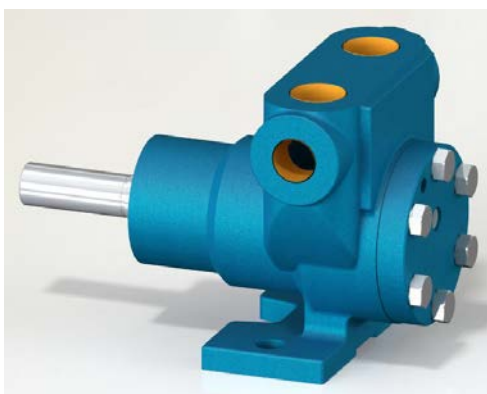

1/2" GAR Internal Eccentric Gear Pump



Performance:

Flow rate	0.6 m ³ /h
Pressure	1 - 15 bar
Temperature	0 - 100 °C
Speed	1400 d/d
Viscosity	100 - 7500 SSU

Technical Features:

- ✓ Internal eccentric gear pump
- ✓ 1/2" threaded ports
- ✓ Compact design
- ✓ Reliable construction thanks to only two moving parts
- ✓ Various material options
- ✓ Available with external bypass and blind cover
- ✓ 230v, three phase 50/60hz motors available
- ✓ Motor and gearbox drive available
- ✓ Manufactured according to CE regulations

Applications:

- ✓ Fuel oil, diesel fuel and gas oil transfer
- ✓ Small scale thermal oil applications including Marlotherm, Duratherm, Paratherm, Multitherm, Mobiltherm and Dowtherm
- ✓ Lubrication applications
- ✓ Coolant transfer
- ✓ Any transfer of low to medium viscosity fluids with lubricating properties
- ✓ Not suitable for fluids containing abrasive particles

Material Options:

- ✓ Pump body, covers: Cast iron, steel cast
- ✓ Gears: Cast iron, steel cast, Spheroidal cast iron
- ✓ Bearings: Snbz 12 bronze, carbon graphite, silicon carbide, hard metal coated steel
- ✓ Sealing: Lip seal

Capacity & Power Table							
Capacity (Q)	Speed (rpm)	Pressure				Viscosity	
		3 Bar	6 Bar	9 Bar	12 Bar		
0.380	900	0.25 HP	0.33 HP	0.50 HP	0.50 HP	750 SSU	
0.540	1400	0.25 HP	0.33 HP	0.50 HP	0.50 HP	100 SSU	
Motor Powers						Motor Powers	
0.12 HP	900 d/d (rpm)					0.50 HP	900 d/d (rpm)
0.17 HP	900 d/d (rpm)					0.75 HP	900 d/d (rpm)
0.33 HP	1400 d/d (rpm)					0.75 HP	1400 d/d (rpm)
0.50 HP	1400 d/d (rpm)					Motor Body	
Motor Body						80	
71							

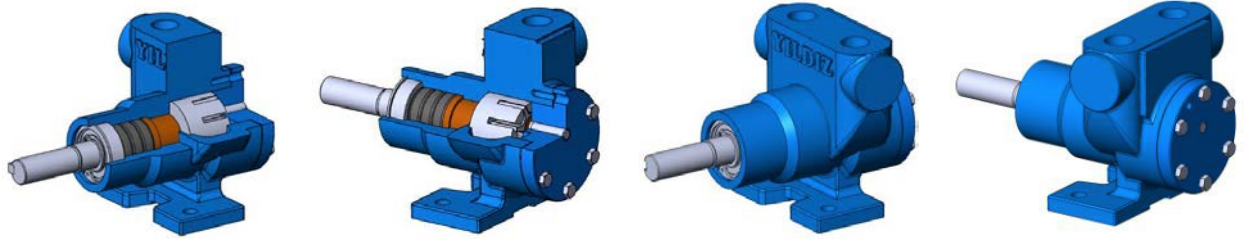

Pump Dimensions - Capacity Graphs:

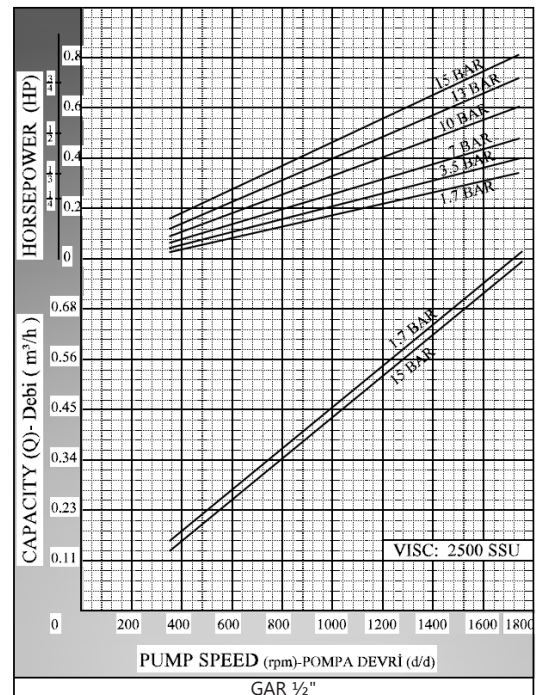
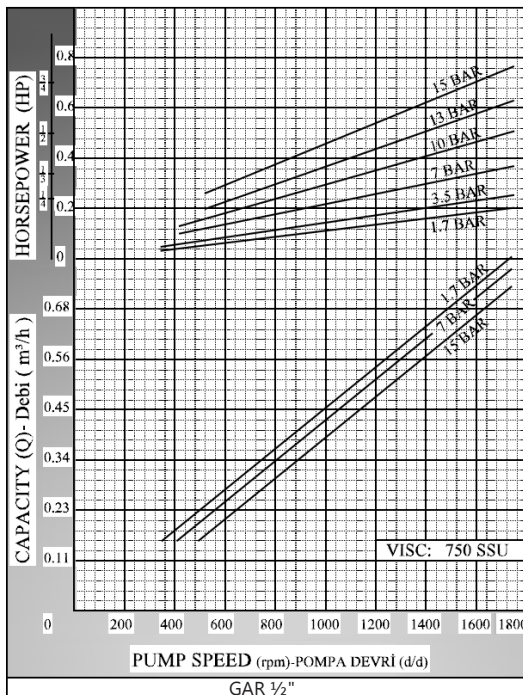
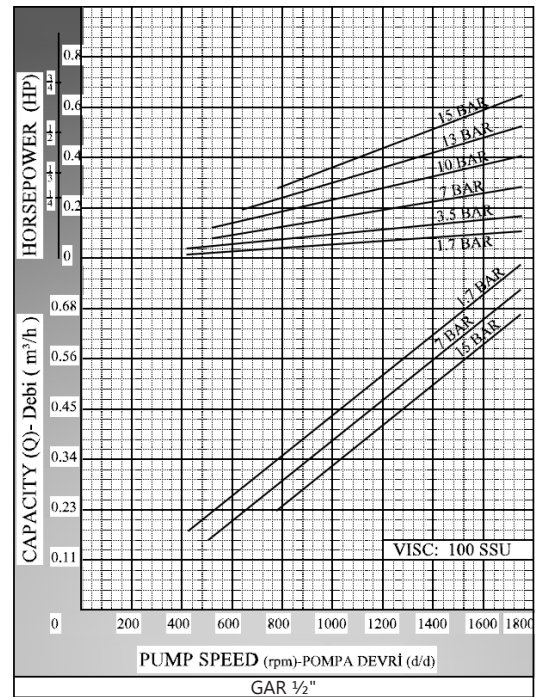
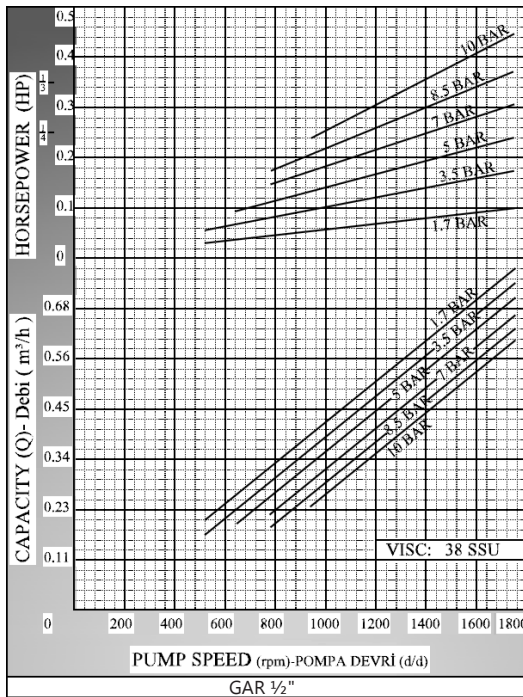

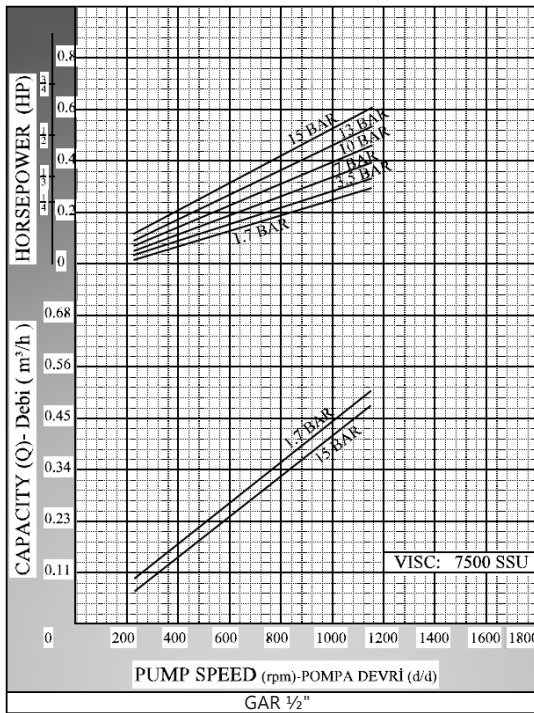

Pump Dimensions:

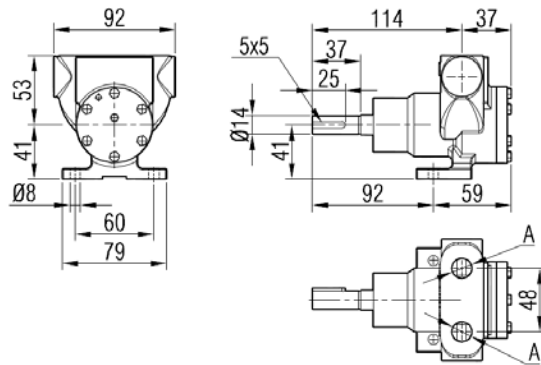

POMPA KODU PUMP CODE	YMK ½"
A	R½"
kg.	2,5

Coupling Dimensions - Motor and gearbox drive:

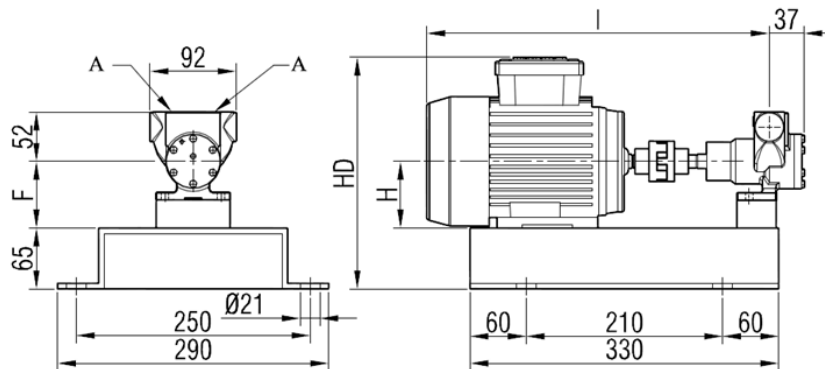

POMPA KODU PUMP CODE	YMK ½"
A	R½"

Motor Power & Speed			I	HD	H	F	Kg
0.16 hp / 0.12 kw	1500 d/d (rpm)	MOTOR 63	332	225	63	63	12
0.25 hp / 0.18 kw	1500 d/d (rpm)						12
0.16 hp / 0.12 kw	750 d/d (rpm)	MOTOR 71	366	247	71	71	14
0.25 hp / 0.18 kw	1000 d/d (rpm)						14
0.34 hp / 0.25 kw	1500 d/d (rpm)	MOTOR 80	396	263	80	80	13
0.25 hp / 0.18 kw	750 d/d (rpm)						16
0.34 hp / 0.25 kw	750 d/d (rpm)						17
0.75 hp / 0.55 kw	1000 d/d (rpm)						17
0.75 hp / 0.55 kw	1500 d/d (rpm)						17
0.75 hp / 0.55 kw	1500 d/d (rpm)						15

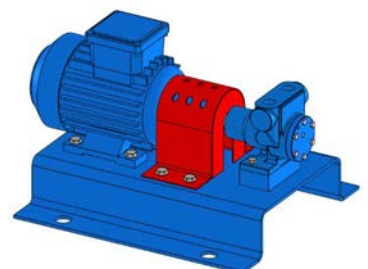



Spare Parts List - Sealed with lip seal:

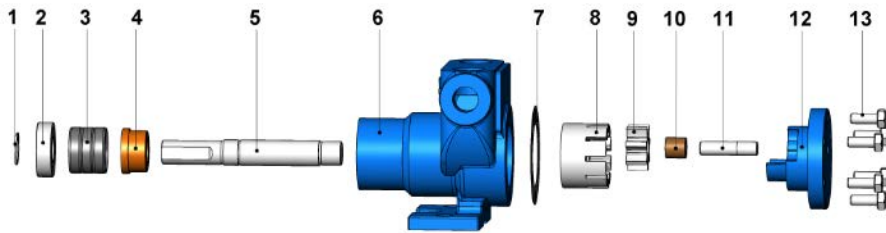

No.	Part Name.	Qty.
1	External Circlip (ø15)	1
2	Ball Bearing (6002 R2S)	1
3	Lip Seal ø15xø27x7	3
4	Casing Bushing	1
5	Shaft	1
6	Casing	1
7	Cover Gasket	1
8	Rotor Gear	1
9	Idler Gear	1
10	Idler Gear Bushing	1
11	Cover Pin	1
12	Blind Cover	1
13	Hex Bolt M6x16	6