



1½" GAR Internal Eccentric Gear Pump



Performance:

Flow rate	5.7 m³/h
Pressure	1 - 14 bar
Temperature	0 - 200 °C
Speed	1400 d/d
Viscosity	100 - 7500 SSU

Technical Features:

- ✓ Internal eccentric gear pump
- ✓ 1½" threaded ports
- ✓ Compact design
- ✓ Reliable construction thanks to only two moving parts
- ✓ Various material options
- ✓ Available with external bypass and blind cover
- ✓ 230v, three phase 50/60hz motors available
- ✓ Motor and gearbox drive available
- ✓ Manufactured according to CE regulations

Applications:

- ✓ Fuel oil, diesel fuel and gas oil transfer
- ✓ Small scale thermal oil applications including Marlotherm, Duratherm, Paratherm, Multitherm, Mobiltherm and Dowtherm
- ✓ Lubrication applications
- ✓ Coolant transfer
- ✓ Any transfer of low to medium viscosity fluids with lubricating properties
- ✓ Not suitable for fluids containing abrasive particles

Material Options:

- ✓ Pump body, covers: Cast iron, steel cast
- ✓ Gears: Cast iron, steel cast, Spheroidal cast iron
- ✓ Bearings: Snbz 12 bronze, carbon graphite, silicon carbide, hard metal coated steel
- ✓ Sealing: Lip seal

Capacity & Power Table						
Capacity (Q)	Speed (rpm)	Pressure				Viscosity
		3 Bar	6 Bar	9 Bar	12 Bar	
3.7	900	1.5 HP	2 HP	3 HP	4 HP	750 SSU
5.7	1400	2 HP	3 HP	4 HP	5.5 HP	100 SSU
Motor Powers		Motor Powers		Motor Powers		
1.5 HP	900 d/d (rpm)	1.5 HP	750 d/d (rpm)	2 HP	750 d/d (rpm)	
1.5 HP	1400 d/d (rpm)	2 HP	900 d/d (rpm)	3 HP	900 d/d (rpm)	
2 HP	1400 d/d (rpm)	3 HP	1400 d/d (rpm)	5.5 HP	1400 d/d (rpm)	
Motor Body		Motor Body		Motor Body		
90		100		112		



Pump Dimensions - Capacity Graphs:

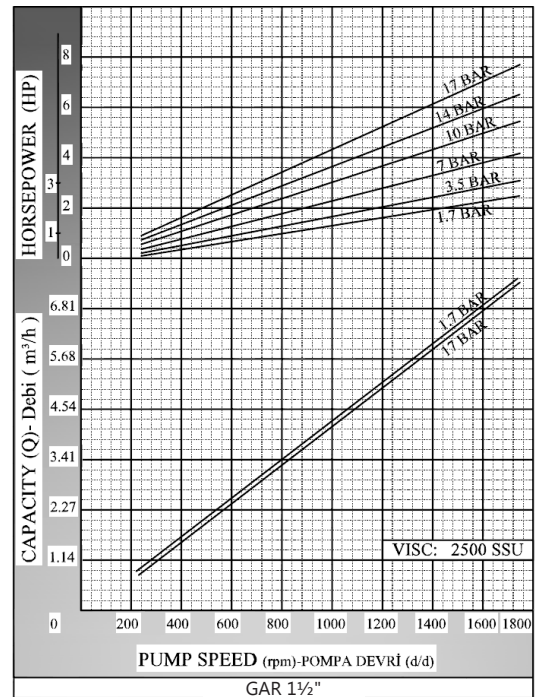
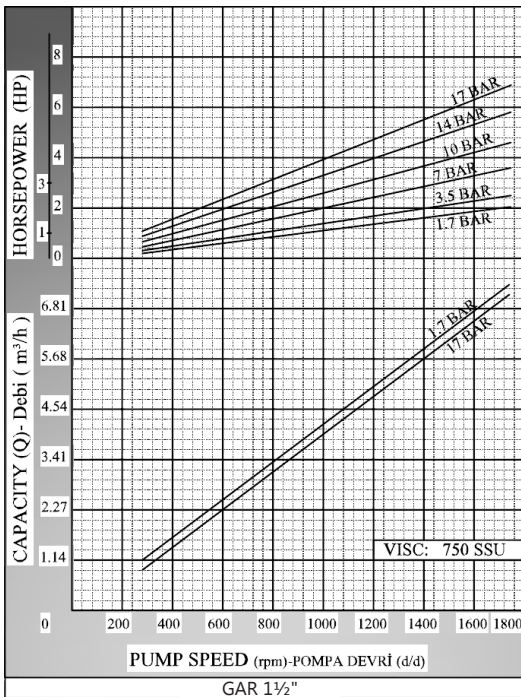
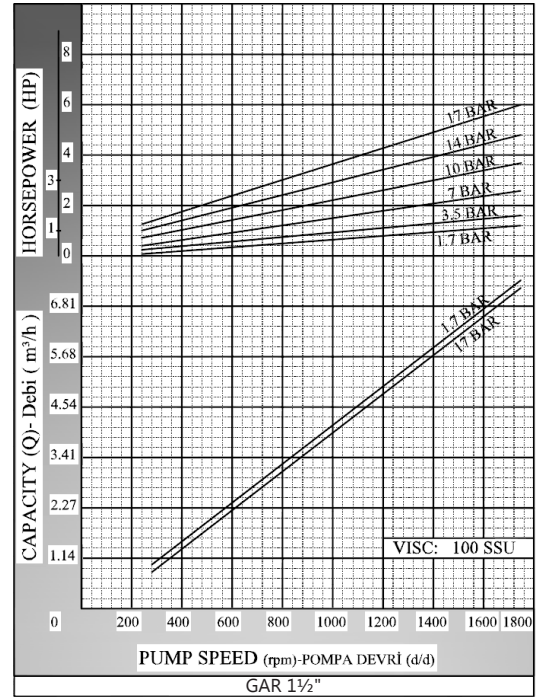
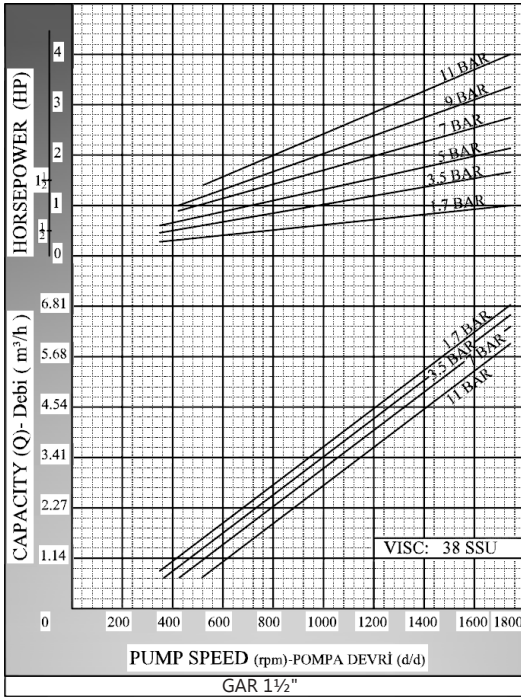

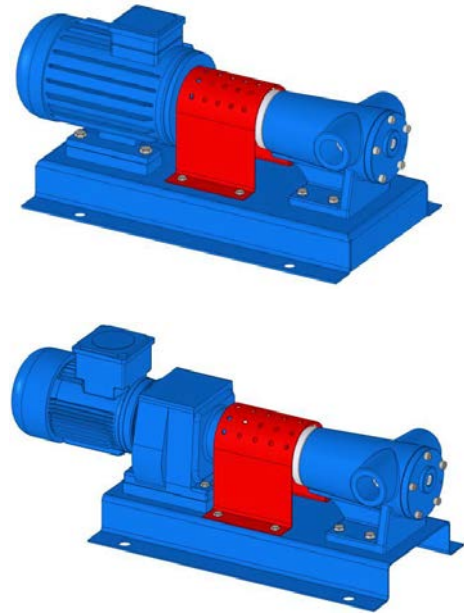
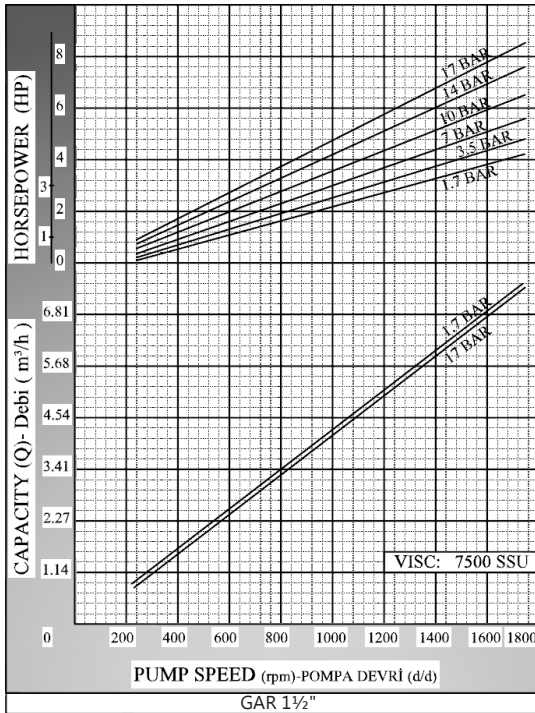

Pump Dimensions:

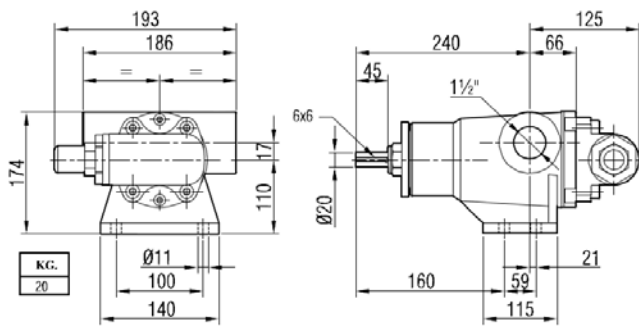
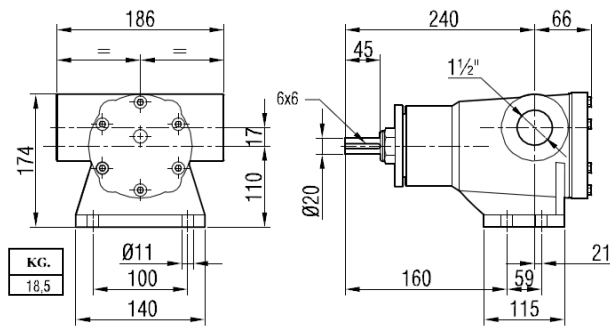



Coupling Dimensions - Motor and gearbox drive:

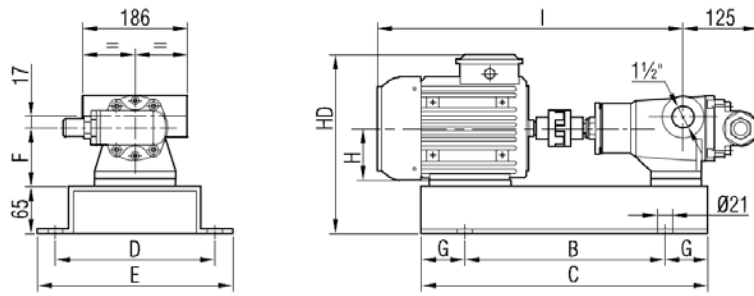

Motor Power & Speed			I	HD	H	B	C	D	E	F	G	Kg			
1 HP / 0.75 kw	1.5 HP / 1.1 kw		569	301	90	430	550	260	300	110	60	44			
900 d/d (rpm)	1400 d/d (rpm)											MOTOR 90S			
1.5 HP / 1.1 kw	2 HP / 1.5 kw		621	310	100	420	620	310	350	112	100	46			
900 d/d (rpm)	1400 d/d (rpm)											MOTOR 90L			
1.5 HP / 1.1 kw	2 HP / 1.5 kw	3-4 HP / 2.2-3 kw	667	312	112	420	620	310	350	112	100	58	58	56	59
750 d/d (rpm)	900 d/d (rpm)	1400 d/d (rpm)										MOTOR 100L			
2 HP / 1.5 kw	3 HP / 2.2 kw	5.5 HP / 4 kw	694	312	112	420	620	310	350	112	100	64	64	65	
750 d/d (rpm)	900 d/d (rpm)	1400 d/d (rpm)										MOTOR 112M			

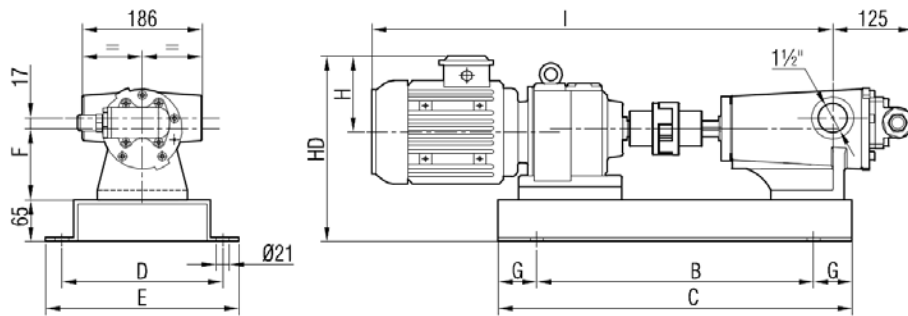

Motor Power & Speed			I	HD	H	B	C	D	E	F	G	Kg
1 HP / 0.75 kw	40/240 d/d (rpm)	IRAM52/80M	708	288	118	430	550	260	300	110	60	57
1.5 HP / 1.1 kw	60/382 d/d (rpm)	IRAM52/90S	727	302	132							60
	30/104 d/d (rpm)	IRAM62/90S	778	301		420	620	310	350	115	100	76
2 HP / 1.5 kw	30/197 d/d (rpm)	IRAM62/90L	803		78							



Spare Parts List - Sealed with mechanical seal, and pressure relief valve on cover:

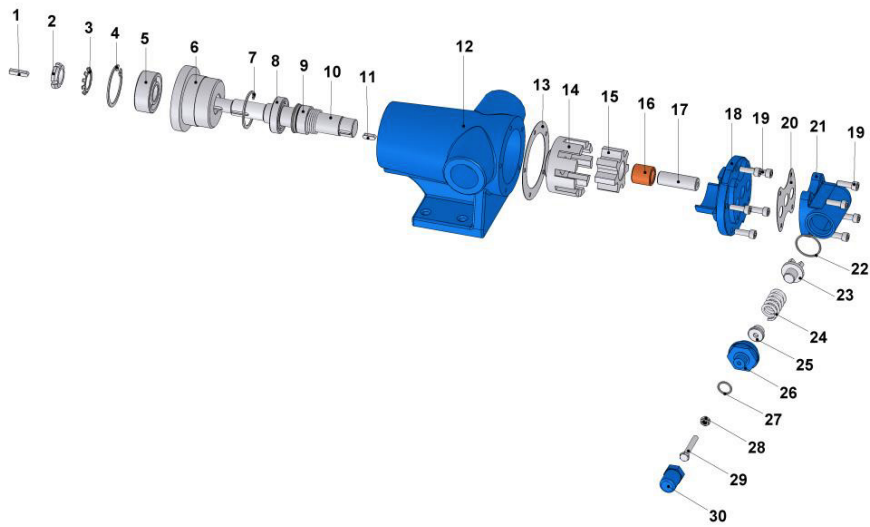

No.	Part Name.	Qty.	No.	Part Name.	Qty.	No.	Part Name.	Qty.
1	Coupling Key 6x6x30 AB	1	11	Key 6x6x30 A	1	21	Pressure Relief Valve - Bypass	1
2	Lock Nut	1	12	Casing	1	22	Bypass O-Ring	1
3	Lock Washer	1	13	Cover Gasket	1	23	Valve	1
4	Pulley Internal Circlip (ø62)	1	14	Rotor Gear	1	24	Spring	1
5	Bearing (62305-2RS)	1	15	Idler Gear	1	25	Washer	1
6	Pulley	1	16	Idler Gear Bushing	1	26	Bypass Cover	1
7	Casing Internal Circlip (ø55)	1	17	Cover Pin	1	27	Cap O-Ring	1
8	Ball Bearing (6006-2RS)	1	18	Cover (w/ Bypass Inlets)	1	28	Nut M8	1
9	Mechanical Seal Ø30	1	19	Inbus Bolt M8x25	9	29	Adjusting Screw M8x55	1
10	Shaft	1	20	Relief Valve Gasket	1	30	Cap	1

Spare Parts List - Sealed with mechanical seal, and with blind cover:

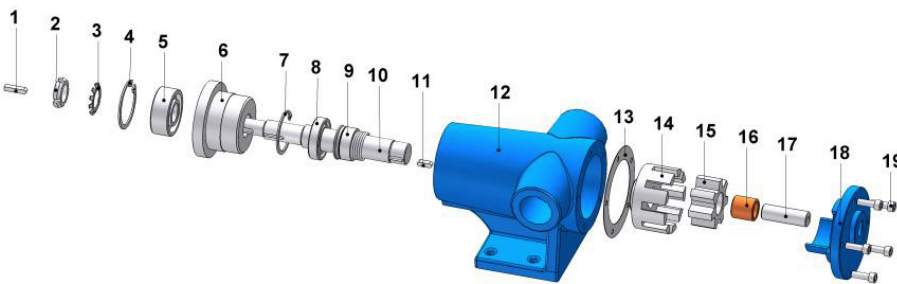

No.	Part Name.	Qty.
1	Coupling Key 6x6x45 AB	1
2	Lock Nut	1
3	Lock Washer	1
4	Internal Circlip (ø62)	1
5	Ball Bearing (62305-2RS)	1
6	Pulley	1
7	Casing Internal Circlip (ø55)	1
8	Ball Bearing (6006-2RS)	1
9	Mechanical Seal Ø30	1
10	Shaft	1
11	Rotor Key 6x6x30 A	1
12	Casing	1
13	Cover Gasket	1
14	Rotor Gear	1
15	Idler Gear	1
16	Idler Gear Bushing	1
17	Cover Pin	1
18	Cover	1
19	Inbus Bolt M8x25	5