

Side channel pump PN 25

SFH

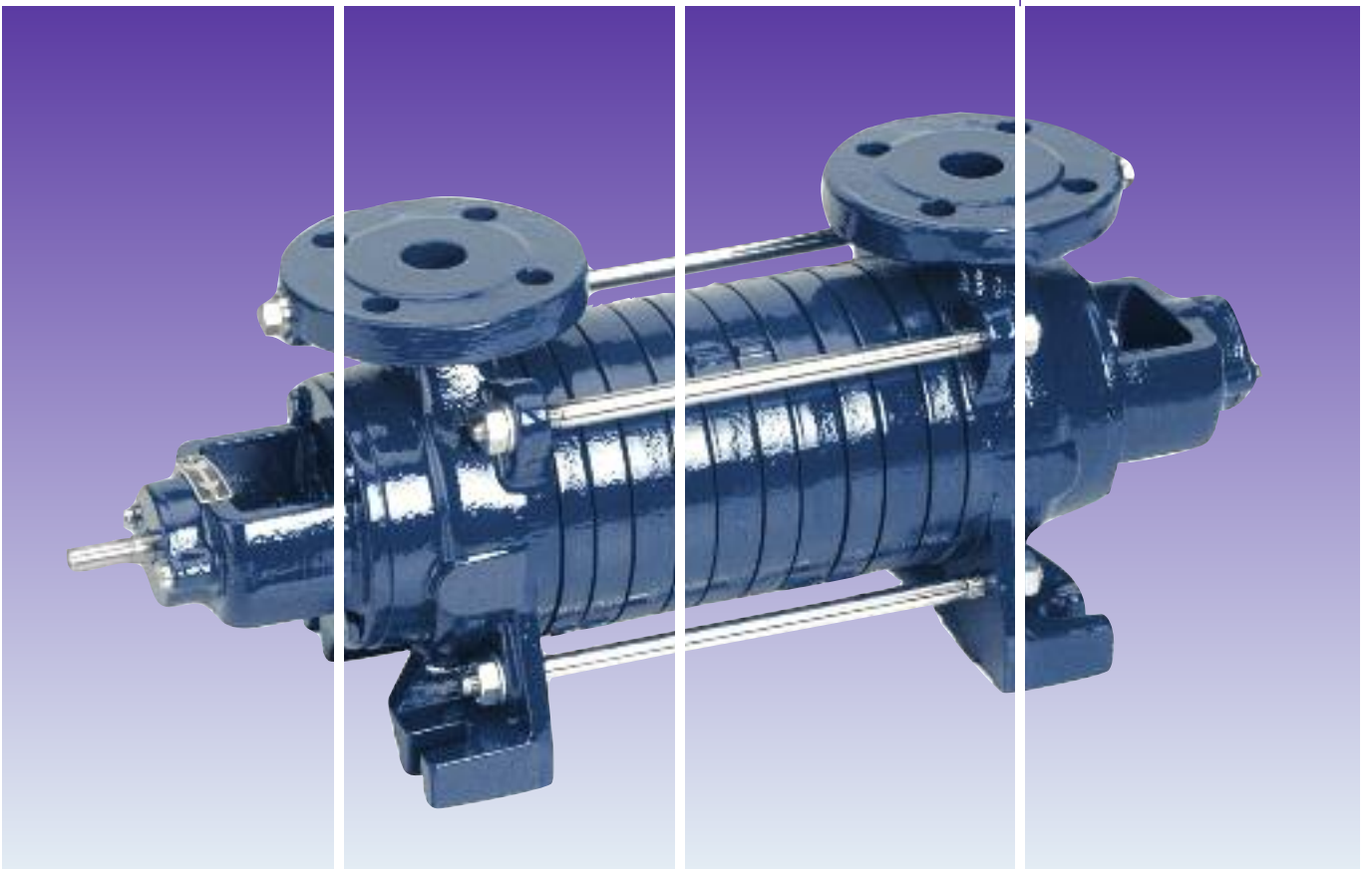

Technical description

Operating data:

Nominal diameter: DN 25 - DN 50
Flow rate: 0,3 - 20 m³/h
Pump head: 5 - 260 m
Speed: up to 1800 rp
Temp.: -20 to +120°C
Design pressure: 25 bar
Viscosity: 0,3 to 230 mPas
Gas content: up to 50%
Max. Motor output: 37 kW
Direction of rotation: right (clockwise)

Design:

Horizontal, transversely divided, self-priming, gas-entraining, side-channel-pump - single stage or multistage

Fields of application:

The pumps can be used wherever a system comparison shows, that our Side Channel Pump causes lower total expenses during its pump live.

Clear or cloudy **liquids** of all types can be pumped, provided that they **contain no abrasives**.

Industries:

- Apparatus engineering
- Chemical and petrochemical industries
- Process engineering
- Energy engineering
- Ship-building
- Agriculture and domestic engineering through to
- Irrigation
- Watering and drainage

Media pumped:

- Distillate
- Distilled water
- Fuel oil
- Boiler feed water
- Hydrocarbons
- Fuels
- Alkalis
- Solvents
- Acids
- Lubricants
- Drinking water

The pumps are also used for **boosting pressure** or for any application, where a self priming pump is necessary or a pump should work trouble free close to the vaporisation point of the liquid.

Characteristics SFH n = 1450 rpm (50 Hz)

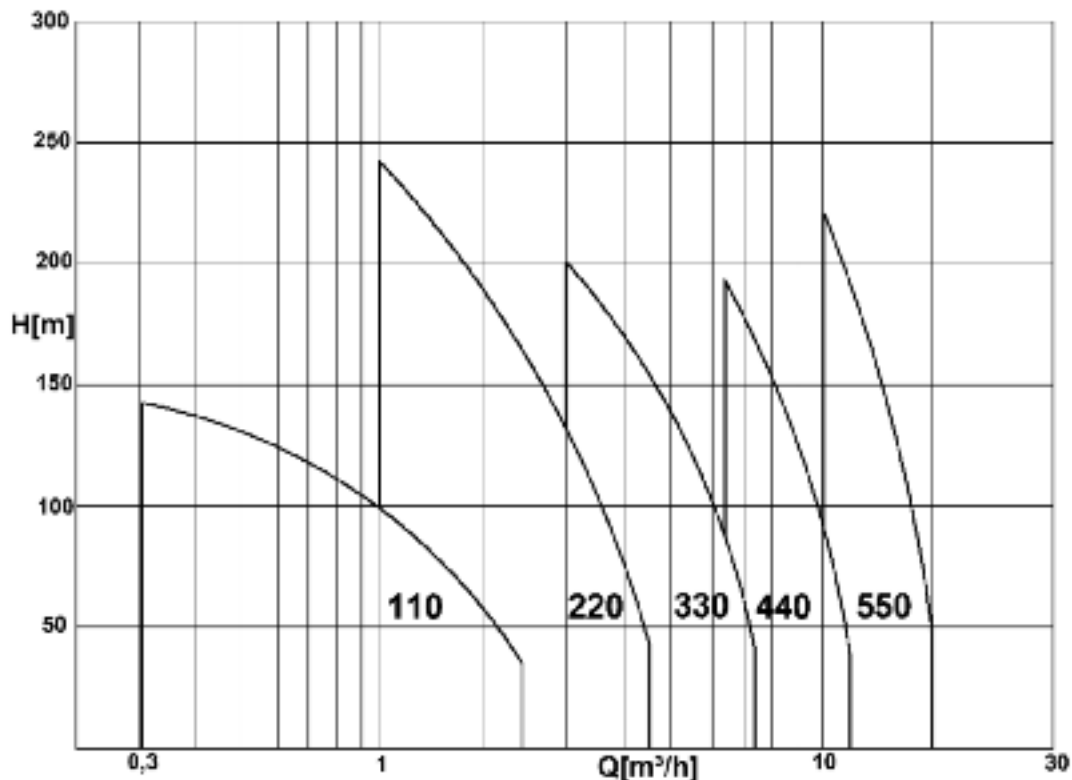

Pumping capacity, fuel consumption, NPSH

see the individual characteristic curves (available on request)

Designation

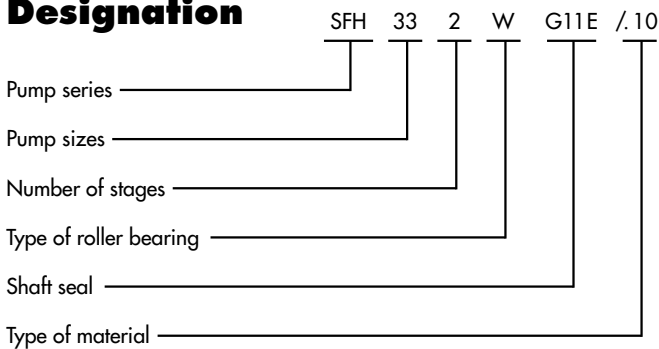

Design features

Casing

Both the suction and discharge casings and the suction and discharge sides are divided transversely. The casing and individual casing sections are sealed with respect to one another by gaskets.

Impellers

Open, star-shaped impellers. Compensation for axial thrust through relief holes. Can be moved axially on the shaft. The impeller diameter cannot be changed.

Shaft

The particularly rigid stainless steel shaft ensures trouble-free operation in all load phases.

Socket position

The suction and discharge casings are directed vertically upwards. The suction casing is usually located on the drive side. (If the pump turns anti-clockwise, then the discharge casing is on the drive side).

Bearing SFH...W

On the drive side, the shaft turns in a greased, single-channel grooved ball bearing conforming to DIN 625. This is packed with grease at the factory for approximately 10.000 operating hours. On the impeller

side, the shaft turns in a stable carbon bearing which is lubricated by the pumped liquid.

Bearing SFH...WW

The shaft turns on both sides in greased, single-channel grooved ball bearings to DIN 625. These are packed with grease at the factory for approx. 10.000 operating hours. In addition for SFH...W and SFH...WW, all intermediate stages are mounted in carbon bearing bushes.

Connections

The suction and discharge connections of each pump

Shaft seals

A mechanical seal is used as standard. This is a single-acting seal which is not cooled or pressurebalanced and has no crossover pipe acc. to DIN 24960.

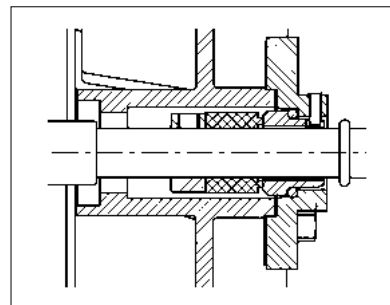

G 11:
for pumping pressures < 16 bar

G 13:
for pumping pressures < 25 bar

Type	G11E	G11T	G13E
seal face	carbon	carbon	SiC
stationary seal	ceramic	ceramic	carbon
O-Ring seal	EP	TTV	EP
Other metal parts	1.4571	1.4571	1.4571

Technical changes reserved

Pump sizes

Pump size	Number of stages					
	1	2	3	4	5	6
110	x	x	x	x	x	
220	x	x	x	x	x	x
330	x	x	x	x	x	x
440	x	x	x	x	x	x
550	x	x	x	x	x	x

are of the same nominal diameter. The connections have round flanges for a design pressure of PN 25. The connections are according to DIN 2501.

The counter flanges are not supplied with the pump. Counter flanges acc. to DIN 2566 may be ordered separately. Other flange connections are not available. (If you require other flanges, then you should consider the SRZ pump for a design pressure of PN 40.)

Accessories

Drive
Fan-cooled IEC three-phase AC squirrel-cage motor

Winding

up to 3 kW: 220-240V/
380-420V
4 kW or higher: 380-420V/
660-725V
Model: B3

Type of protection: IP 55/IP 54
Temperature class: F
Operating mode: Continuous operation S1

Coupling

Flexible coupling without spacer sleeve

Protection against accidental contact

Coupling guard conforming to EN 294.

Base plate

Welded profiled steel or cast iron of torsionally rigid design.

Paint

Standard paint: RAL 5002 blue. Other paints available upon request.

Acceptance tests

The operating point is guaranteed with the following tolerances:

Pump head H: ± 10 %
Flow rate Q: ± 10 %

Power consumption P: + 14 %
Acceptance tests to DIN EN ISO 9906 (1 operating point) can be carried out upon request.

Maximum test pressure:

1,3 x maximum admissible pump discharge pressure.

Benefits

Side channel stage enables gases to be entrained

Robust grooved ball bearing, permanent grease lubrication, maintenance-free

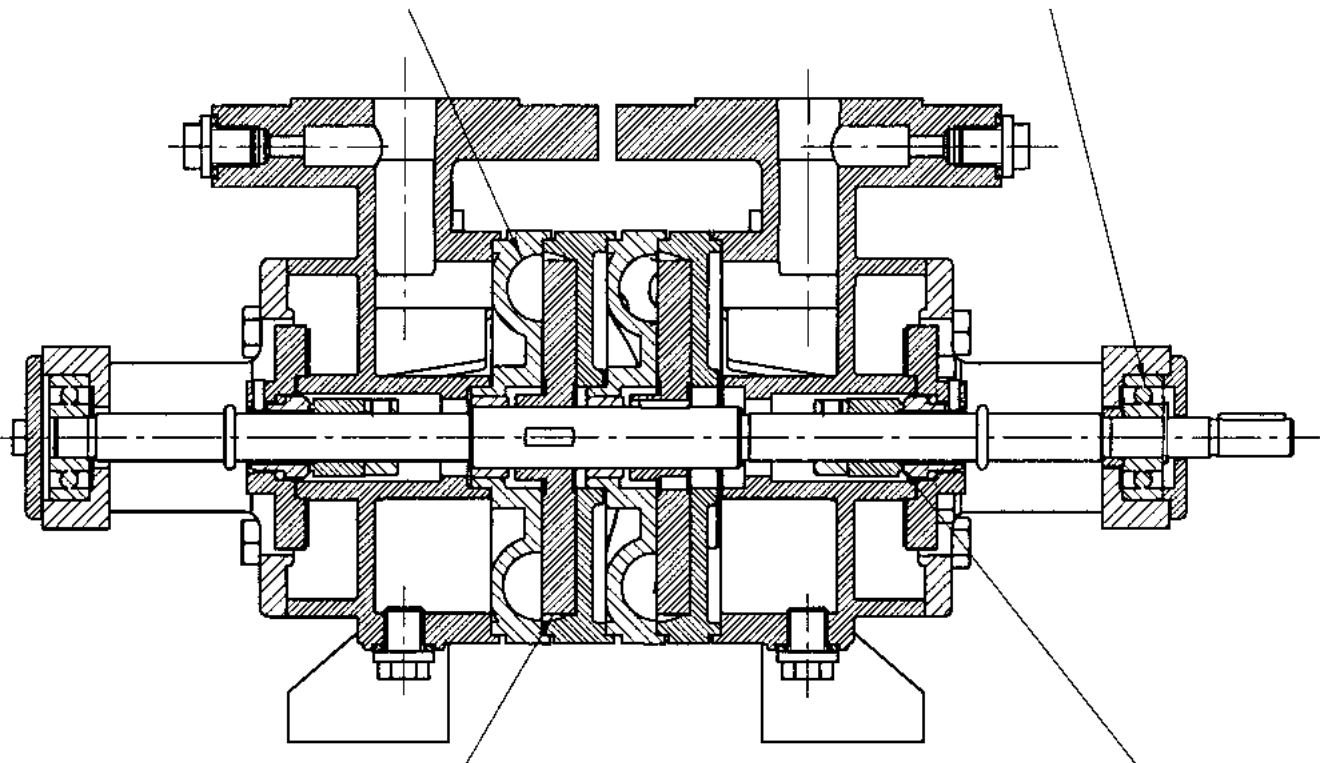

Open impellers guarantee a high self-priming capability

Hydraulic compensation for axial thrust

Standard mechanical seal acc. to DIN 24960, adapted to the requirements of the intended application. Changing of mechanical seal possible without disassembling the pump.

Materials

Pump material	Material code 10	Material code 12	Material code 32
Suction casing	cast iron GG 25	cast iron GG 25	stainless steel 1.4408
Discharge casing	cast iron GG 25	cast iron GG 25	stainless steel 1.4408
Stage casing	cast iron GG 20	cast iron GG 20	stainless steel 1.4470
Side Channel casing	cast iron GG 20	cast iron GG 20	stainless steel 1.4470
Shaft	1.4021	1.4021	stainless steel 1.4571
Impeller	Brass CuZn40Al1	stainless steel 1.4059	stainless steel 1.4581
Bearing bracket	cast iron GG 20	cast iron GG 20	cast iron GG 20
Bearing bush	bronze	carbon	carbon
bolts	steel	steel	steel

Dimensions SFH...W/SFH...WW

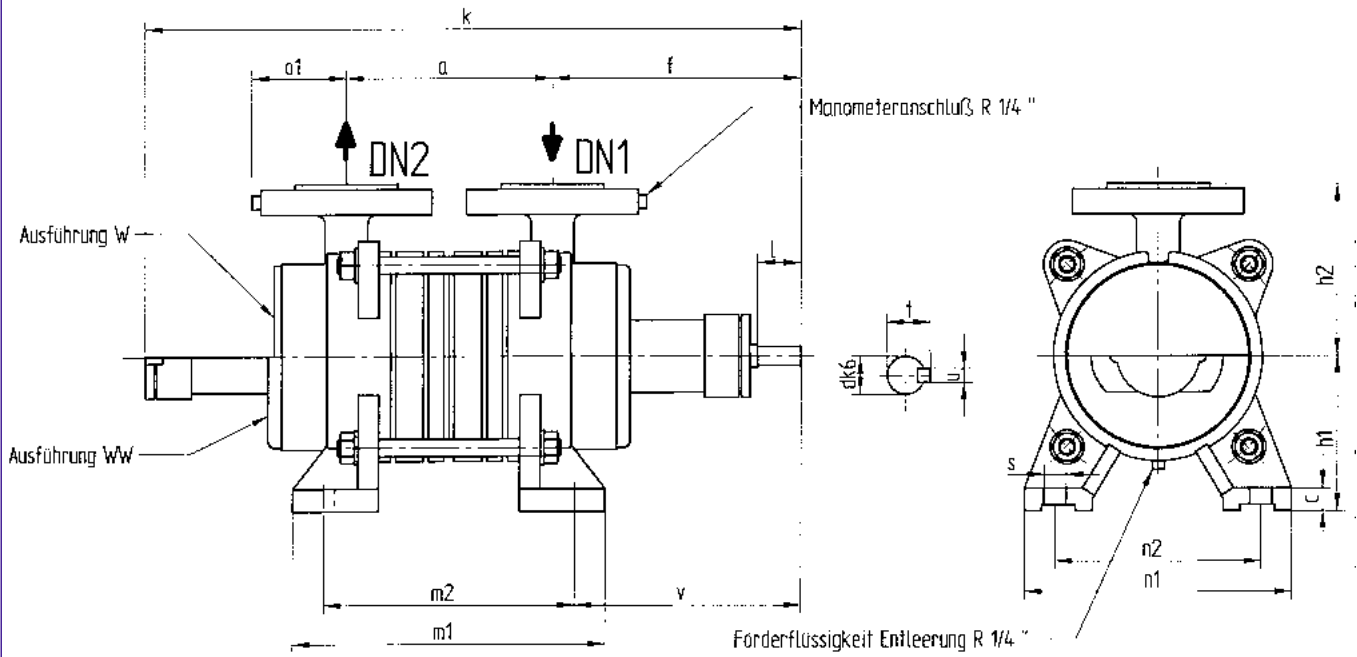

mm

size	DN ₁ ²⁾ DN ₂ ²⁾	a	c	dk ₆	f	h ₁	h ₂	k	l	m ₁	m ₂	n ₁	n ₂	s	t	u	v	0 ₁
111	25	120	13	11	145	90	100	382	25	182	146	156	120	13	12,6	4	132	55,0
112		382						182		146								
113		416						216		180								
114		450						250		214								
115		484						284		248								
221	32	145	15	16	159	112	112	420	40	214	178	218	160	13	18,1	5	142	75,0
222		420						214		178								
223		460						254		218								
224		500						294		258								
225		540						334		298								
226		580						374		338								
331	32	145	15	16	159	112	112	420	40	214	178	218	160	13	18,1	5	142	75,0
332		420						214		178								
333		460						254		218								
334		500						294		258								
335		540						334		298								
336		580						374		338								
441	40	155	20	19	205	132	132	523	45	195	159	218	160	13	21,5	6	203	80,0
442		578						250		214								
443		633						305		269								
444		688						360		324								
445		743						415		379								
446		798						470		434								
551	50	170	20	24	217	150	140	558	50	220	185	218	160	13	26,9	8	210	87,5
552		633						295		260								
553		708						370		335								
554		783						445		410								
555		858						520		485								
556		933						595		560								

²⁾ DN = DIN 2501, PN 25

Installation plan SFH...W + SFH...WW

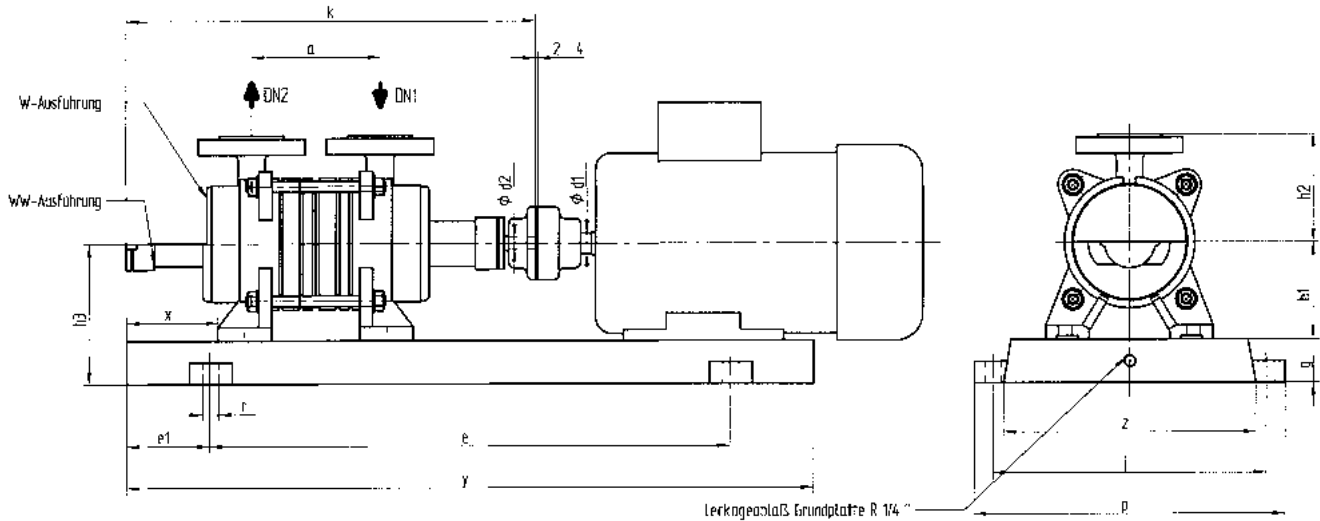

mm

size	IP55 1450 rpm kW Motor	coup- ling	base- plate	DN ₁ DN ₂ 1)	a	d ₁	d _{2,k6}	e	e ₁	g	h ₁	h ₂	h ₃	i	k *)	p	r	x	y	z	stonebolt	
111	0,37 0,55	71 80	58	180a	25	120	14 19	11	485	78	40	90	100	130	255	382	290	15	85	640	235	M12 x 200
112	0,55 0,75 1,1	80 80 90S	58 58 68	180a	25	120	19 19 24	11	485	78	40	90	100	130	255	382	290	15	85	640	235	M12 x 200
113	0,75 1,1 1,5	80 90S 90L	58 68 68	181	25	154	19 24 24	11	550	90	45	90	100	135	305	416	340	15	85	730	270	M12 x 200
114	1,1 1,5 2,2	90S 90L 100L	68 68 80	181 181 182	25	188	24 24 28	11	550 550 650	90 90 100	45	90	100	135 135 145	305 305 308	340	15	85	730 730 850	270 270 280	M12 x 200	
115	1,1 1,5 2,2	90S 90L 100L	68 68 80	181 182 182	25	222	24 24 28	11	550 650 650	90 100 100	45	90	100	135 135 145	305 308 308	340	15	85	730 850 850	270 280 280	M12 x 200	
221	0,55 0,75 1,1 1,5	80 80 90S 90L	58 58 68 68	181	32	145	19 19 24 24	16	550	90	45	112	112	157	305	420	340	15	108	730	270	M12 x 200
222	1,1 1,5 2,2	90S 90L 100L	68 68 80	181 181 182	32	145	24 24 28	16	550 550 650	90 90 100	45	112	112	157	305 305 308	420	340	15	108	730 730 850	270 270 280	M12 x 200
223	1,5 2,2 3,0 4,0	90L 100L 100L 112M	68 80 80 80	182	32	185	24 24 28 28	16	650	100	45	112	112	157	308	460	340	15	108	850	280	M12 x 200
224	2,2 3,0 4,0 5,5	100L 100L 112M 132S	80 80 80 95	182 182 182 183	32	225	28 28 28 38	16	650 650 650 730	100 100 100 150	45 45 45 50	112	112	157 157 157 182	308 308 308 385	500	340 340 340 420	15 15 15 18	108	850 850 850 1030	280 280 280 320	M12 x 200 M12 x 200 M12 x 200 M16 x 200
225	3,0 4,0 5,5	100L 112M 132S	80 80 95	183	32	265	28 28 38	16	730	150	50	112	112	162 162 182	385	540	420	18	108	1030	320	M16 x 200
226	4,0 5,5 7,5	112M 132S 132M	80 95 95	183	32	305	28 38 38	16	730	150	50	112	112	162 182 182	385	580	420	18	108	1030	320	M16 x 200

1) DN = DIN 2501, PN 25*)

*) only valid for SFH...WW

size	IP55		coup- ling	base- plate	DN ₁ DN ₂ 1)	a	d ₁	d _{2 k6}	e	e ₁	g	h ₁	h ₂	h ₃	j	k *)	p	r	x	y	z	stonebolt	
	1450 kW	rpm Motor																					
331	0,75	80	58	181	32	145	19	16	550	90	45	112	112	157	305	420	340	15	108	730	270	M12 x200	
	1,1	90S	68	24																			
	1,5	90L	68	24																			
332	1,5	90L	68	181	32	145	24	16	550	90	45	112	112	157	305	420	340	15	108	730	270	M12 x200	
	2,2	100L	80	28			650																100
	3,0	100L	80	28																			
333	2,2	100L	80	182	32	185	28	16	650	100	45	112	112	157	308	460	340	15	108	850	280	M12 x200	
	3,0	100L																					
	4,0	112M																					
334	3,0	100L	80	182	32	225	28	16	650	100	45	112	112	157	308	500	340	15	108	850	280	M12 x200	
	4,0	112M	80	28			650																100
	5,5	132S	95	38																			
335	4,0	112M	80	183	32	265	28	16	730	150	50	112	12	162	385	540	420	18	108	1030	320	M16 x200	
	5,5	132S	95	38																			
	7,5	132M	95	38																			
336	4,0	112M	80	183	32	305	28	16	730	150	50	112	112	162	385	580	420	18	108	1030	320	M16 x200	
	5,5	132S	95	38																			
	7,5	132M	95	38																			
441	1,5	90L	68	181	40	155	24	19	550	90	45	132	132	177	305	523	340	15	61	730	270	M12 x200	
	2,2	100L	80	28			650																100
	3,0	100L	80	28																			
442	3,0	100L	80	182	40	210	28	19	650	100	45	132	132	177	308	578	340	15	61	850	280	M12 x200	
	4,0	112M																					
443	4,0	112M	80	182	40	265	28	19	650	100	45	132	132	177	308	633	340	15	61	850	280	M12 x200	
	5,5	132S	95	38			730																150
	7,5	132M	95	38																			
444	5,5	132S	95	183	40	320	38	19	730	150	50	132	132	182	385	688	420	18	61	1030	320	M16 x200	
	7,5	132M	183	38			730																50
	11,0	160M	184	42																			
445	7,5	132M	95	184	40	375	38	19	930	150	55	132	132	187	400	743	445	20	61	1230	340	M16 x200	
	11,0	160M		42																			
446	7,5	132M	95	184	40	430	38	19	930	150	55	132	132	187	400	798	445	20	61	1230	340	M16 x200	
	11,0	160M		42																			
	15,0	160L		42																			
551	3,0	100L	80	182	50	170	28	24	650	100	45	150	140	195	308	558	340	15	112	850	280	M12 x200	
	4,0	112M																					
552	5,5	132S	95	183	50	245	38	24	730	150	50	150	140	200	385	633	420	18	112	1030	320	M16 x200	
	7,5	132M	183	38			730																50
	11,0	160M	184	42																			
553	7,5	132M	95	184	50	320	38	24	930	150	55	150	140	205	400	708	445	20	112	1230	340	M16 x200	
	11,0	160M		42																			
	15,0	160L		42																			
554	11,0	160M	95	7	50	395	42	24	940	230	100	150	140	260	550	783	590	28	112	1400	490	M24 x320	
	15,0	160L	95	42																			
	18,5	180M	110	48																			
555	11,0	160M	95	7	50	470	42	24	940	230	100	150	140	260	550	858	590	28	112	1400	490	M24 x320	
	15,0	160L	95	42																			
	18,5	180M	110	48																			
	22,0	180L	110	48																			
556	15,0	160L	95	8	50	545	42	24	1060	270	100	150	140	260	600	933	640	28	112	1600	540	M24 x320	
	18,5	180M	110	48																			
	22,0	180L	110	48																			
	30,0	200L	125	55																			
	37,0	225S	140	60																			

1) DN = DIN 2501, PN 25*)

*)only valid for SFH...WW



address:
SERO PumpSystems GmbH
Industriestraße 31
D-74909 Meckesheim near Heidelberg
Germany

contact:
Phone + 49 (62 26) 92 01-0
Fax + 49 (62 26) 92 01-40
info@seroweb.de
sales@seroweb.de
service@seroweb.de

information:
www.seroweb.de